

Return Service Requested

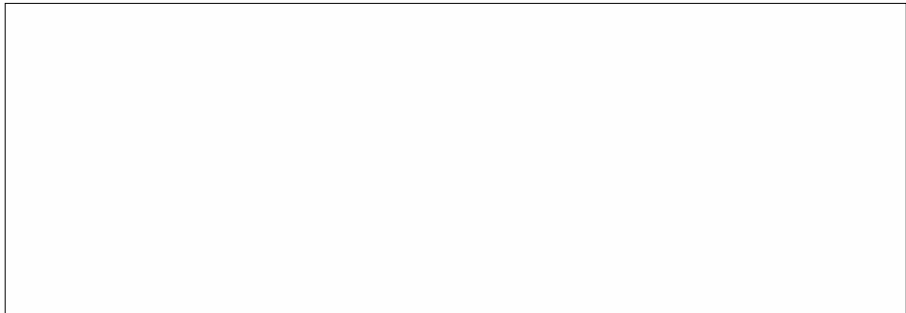

PARTS SPECIALS



Replacement Battery Tray Pins
 Replacement stainless steel battery tray pins. Easier Operation and will not rust.



Part #: 06-54592-HOG

\$31.⁹⁹ ea.



Battery Tray for C-2 Thomas
 Replacement battery tray for C-2 Thomas. You won't have to get the skid loader to pull the batteries out anymore!

Part #: 06-37275HOG

\$167.⁷⁰ ea.

New IC Fresh air close off for Driver's Area on those cold days! 6 snaps to install.

Part #: CE-FAC



\$16.⁷⁷ ea.



International Yellow Full Winterfront



Part #: ZEDWF2195LY

\$69.⁹⁹ ea.



Motor Assembly
 New style door control ASM for 2 - 2

Part #: TBB159028

\$653.⁴⁵ ea.



Fleetrite Allison TES 295 Synthetic Transmission Fluid, 55 gallon drum

Part #: FLTATF295D

\$1753.³⁹ ea.

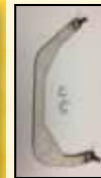

Replaces plastic link on Freightliner passenger side front heater, instead of replacing whole assembly or tying open.

Part #: KHG863HOG

\$57.⁶⁰ ea.

Our Parts Department carries an extensive inventory of "All Makes" products and can supply everything needed to keep your vehicles running smoothly. Our goal is to make ordering parts as easy as possible!

Stretch your parts dollars with these special offers!

800.866.3104

To sign up for weekly parts specials, email marketing@hoglundbus.com



FEBRUARY 2017

— **School Bus Flyer** —



Did you know you can sign up for OnCommand Parts & Service Portal through Hogleund Bus Company and get a CYY # to access parts and service iKNow articles?

OnCommand Service & Parts Information provides technicians access to the most up-to-date, VIN-based service and parts information. It's an invaluable centralized source of essential service information to help improve vehicle repairs and maintenance, repair shop efficiency, technical knowledge and vehicle uptime.

Features and Benefits:

- With a subscription, technicians can gain real-time, up-to-date VIN-based service and parts information.
- Locate technical information by major component group, model, vendor, engine and feature code.
- Service manuals and bulletins are illustrated and include repair, overhaul, troubleshooting tips and diagnostic information.
- Documents and notes can easily be uploaded and attached per VIN
- Access to IKnow technical database to search service articles by entering symptom terms and/or descriptions.

With a CYY login, you will have access to OnCommand's service and parts portal. If you would like to sign up for this fee-based service portal, please contact Cassie Angell at 763.271.2973, mnpartscoord@hoglundbus.com.

INSIDE THIS ISSUE:

- New & Used Inventory
- Parts Specials
- Service Information
- Service Special

Iowa Sales Team

Marc Steele (Northern IA)
 C: 641.512.3854
 E: marcsteele@hoglundbus.com

Brian Glenney (Central IA)
 C: 641.751.4365
 E: brianglenney@hoglundbus.com

Danny Thede (Southern IA)
 C: 641.750.6428
 E: danny.thede@hoglundbus.com

2017 COURSE CATALOG

Hoglund Bus Company	<ul style="list-style-type: none"> • OnCommand Connection • PSI Propane Training • MaxxForce 7, DT, 9, 10 • CE Bus Program (Brakes, Electrical)
IC Bus	<ul style="list-style-type: none"> • 2007 Emissions Fundamentals • Navistar Safety • OnCommand Service & Parts Information • ServiceMaxx Introduction and Usage • MaxxForce DT, 9, 10 - Engine Overview — Brakes, Electrical, Door Adjustments
Navistar	<ul style="list-style-type: none"> • OnCommand Connection - Paid subscription available to purchase through Hogleund Bus Co., contact mnpartscoord@hoglundbus.com
Meritor	<ul style="list-style-type: none"> • Automatic Slack Adjuster • Foundation Brake

DIRECT LINES:

Sales: 800.866.3105
Parts: 800.866.3104
Service: 877.752.4733
Tech Line: 763.271.2982



www.hoglundbus.com

**Remote Diagnostics for all makes of vehicles!
 OnCommand Connection**

Empower your fleet operations with more visibility than ever before!

OnCommand™ Connection is the industry's first and only open architecture remote diagnostic system for fleets of all makes and models of vehicles. Use OnCommand Connection to pro-actively identify potential problems, improve vehicle uptime, control maintenance and lower repair costs.

Key Features & Benefits:

- Reduce en-route events by scheduling maintenance & repairs.
- Map tools that plot bus locations.
- Generate real-time comprehensive vehicle health reports.
- Understand fault codes quickly and easily with descriptions in non-technical terms.
- Gain more insight with fault code action plans that provide severity information and recommend solutions.

Allison 1000 and 2000 Transmission Fluid Loss from Main Housing Breather During Cold Weather Operation

Applies to: Allison 1000 and 2000 Transmissions **Symptoms:** Transmission fluid loss from breather during cold weather operation

Resolution: When diagnosing transmission fluid leaking out of the breather on 1000 and 2000 transmission, first determine if the fluid level is proper and dipstick markings are accurate. If the condition persists, remove the fill tube and dipstick. Create a 1.5 - 2.0mm (0.06-0.08 inch) vent hole through the fill tube sidewall as close to the top of the tube as possible without being obstructed by the dipstick (Figure 1).

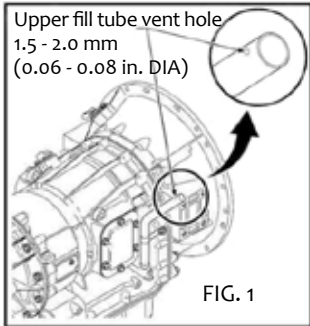

Caution: If the transmission fluid level is too high due to overfill, aerated fluid may be forced out through the fill tube or cap vent. Do not locate the fill tube opening near hot objects such as the exhaust system where exiting fluid could create a hazard. Fill tubes should also be vented below the fill tube seal and main case (Figure 2). Determine if lower vent is present, and if not, create a 1.5-2.0mm (0.06-0.08 inch) vent hole through the fill tube sidewall 31.75mm (1.25 inch) below the fill tube seal flange. Remove burrs that may damage the fill tube seal.

Continued leaking out the main housing breather after checking dipstick calibration, verifying fluid level, and venting the fill tube indicates an internal pressure loss and will require further investigation.

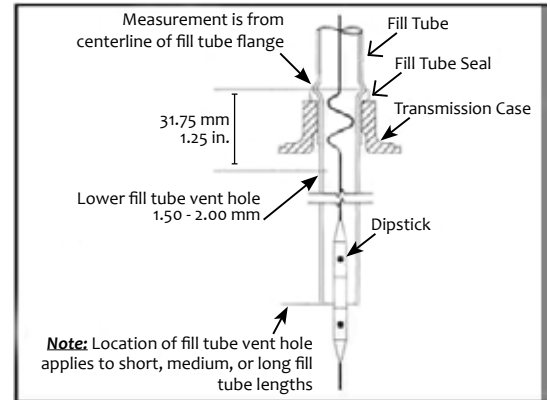

Reference: iKnow Article IK1300054

Steering Fluid: Applies to all models

All vehicles manufactured in 2017 will be factory filled with ATF fluid. This will be easily identified by red colored fluid in the steering reservoir. The new ATF fluid is backwards compatible with earlier built vehicles. Please note that every time steering fluid will be swapped a complete steering system flush is required. For ease of service there are two other applicable fluids that can be used referenced in the parts section of this iKnow. It is recommended to use the chart below to determine what fluid best fits the application of the users fleet or vehicle.

Service Parts information			
Kit Desc.	Part #	Qty. Needed	Notes
ATF Fluid	FLTPSDX3Q	as needed	
PSF Fluid	FLTPSF32	as needed	
15W40 Engine Oil	FLTL15W40G	as needed	FLTL15W40GCD Canada Gallon

Caution: ATF and PSF are the ONLY acceptable fluids for vehicles equipped with brake booster hydraulic systems.

February Service Special - 4 Camera Install

\$349.⁰⁰

Service includes:
Installation of any four camera system for all school bus makes.

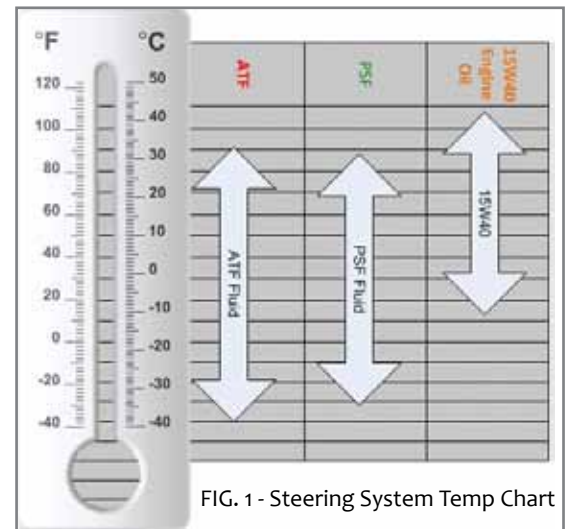

FIG. 1 - Steering System Temp Chart

Reference: iKnow Article IK0500058

Front Line Tech Support



We invite you to contact our Tech Helpline with any technical or training questions you may have.

Doug Yager

D: 763.271.2982 • C: 763.350.2597

E: service@hoglundbus.com

MOBILE SERVICE AVAILABLE

Hoglund offers Mobile Service throughout Minnesota and parts of Iowa. Contact Tom Paulson for details and to schedule a service call.

Tom Paulson

D: 763.271.2962

E: mobileadvisor@hoglundbus.com

WARRANTY SUPPORT

We invite you to contact our Warranty Department with any questions you might have.

Brian Tesmer

D: 763.271.2978

E: brian.tesmer@hoglundbus.com

NEW BUS INVENTORY

PASS	YEAR	SPEC	MAKE	ENGINE	BRK
14	2017	1743	Transit	Ford	H
22	2017	1745	Collins	Ford	H
44+	2017	1705	IC - CE	ISB/240	A
65	2017	1703	IC - CE	ISB/240	A
65	2017	1706	IC - CE	ISB/240	A
65	2017	1707	IC - CE	ISB/240	A
77	2016	1605	IC - CE	MXDT/230	A
77	2017	1708	IC - CE	ISB/250	A
77	2017	1729	IC - CE	Propane/270	A
77	2017	1733	IC - CE	ISB/240	A
77	2017	1744	IC - CE	ISB/250	A
84	2017	1740	IC - RE	MXDT/285	A

USED BUS SPOTLIGHT



File: 22475AI
Year: 2014
Make: IC-CE
Pass: 65
Odometer: 39,046
Engine: MXDT/260
Fuel: Diesel
Brake: Air

\$64,000

Financing & Leasing Available

THERE'S REAL POWER IN HAVING OPTIONS.



8.8L

270hp @ 2600

565 ft-lb @ 1500

Displacement

Rated Horsepower

Rated Torque



8.8L

265hp @ 2800

545 ft-lb @ 1800

USED BUS INVENTORY

PASS	YEAR	MAKE	ENGINE	BRK	ODO
Large Conventional Buses 65 to 77 Passenger					
71	2014	IC	MXDT/245	A	47,434
71	2014	IC	MXDT/245	A	45,887
65	2014	IC	MX7/240	H	40,393
65	2014	IC	MXDT/260	A	39,046
65	2014	IC	MXDT/260	A	31,639
65	2014	IC	MXDT/260	A	29,461
65	2014	IC	MXDT/245	A	54,037
65	2014	IC	MXDT/245	A	55,008
65	2014	IC	MXDT/245	A	48,803
65	2014	IC	MXDT/230	H	30,620
65	2014	IC	MXDT/230	A	42,237
65	2014	IC	MXDT/230	A	43,805
65	2014	IC	MXDT/230	A	45,094
65	2014	IC	MXDT/230	A	42,246
65	2014	IC	MXDT/230	A	38,902
65	2014	IC	MX7/240	A	32,509
65	2014	IC	MX7/240	A	36,331
65	2014	IC	MX7/260	A	38,275
65	2013	IC	MX7/220	A	40,483
65	2011	IC	MX7/215	A	84,229
65	2011	IC	MX7/215	A	56,262
65	2010	IC	MX7/215	A	73,225
65	2010	IC	MX7/215	A	78,219
77	2008	Frtl	Merc/210	A	95,059
71	2008	Frtl	Cat C7/210	A	109,247
65	2005	IC	VT365/215	H	96,947
10 - 64 Passenger Buses					
59	2012	IC	MX7/220	A	45,107
18	2010	Chev	Diesel	H	80k
59	2008	TH	Merc/190	H	58,872
46	2007	BB	CAT C7	A	132,846
27	2005	Chev	Gas	H	122,941
Special Needs & Lift Buses					
Lift	2014	IC	MXDT/230	A	31,801
33+	2005	IC	DT466/210	A	112,209

TRADE SHOWS

3/25 - 3/26 - NSBA - National School Boards Association, Colorado Convention Center, Denver

* If you're headed to Denver,
Hoglund Bus Co., Inc. will be at NSBA for the first time. Please stop by our booth to visit.



IOWA PUPIL TRANSPORTATION ASSOCIATION™

Save the Date for IPTA's Regional Meetings!
 Check out their website for sign up! www.4IPTA.org

Dates and City Locations:

April 4th - April 6th	LeMars, Harlan, Creston
April 11th - April 13th	Waverly, Maquoketa, Fairfield
April 18th - April 20th	Mason City, Fort Dodge, Newton